



SMART STREET LIGHT SYSTEM USING CLOUD TECHNOLOGY

Mrs K APSANA, Mrs. G AFRIN, Ms J SABITHA ,
Assistant Professor^{1,2,3}

Department of ECE,

Viswam Engineering College (VISM) Madanapalle-517325 Chittoor District, Andhra Pradesh, India

Abstract— The current infrastructure, road lighting commonly relies on the utilization of HID (High-Intensity Discharge) lamps, which consume substantial amounts of energy. Additionally, its intensity cannot be altered as per necessity. Therefore, the “Automatic Street light controller circuit using LDR and Relay” overcomes these restrictions using an LDR (Light Dependent Resistor) and IR sensor. An Arduino board is employed for this objective, serving as a programmed device capable of executing customized instructions. The LDR detects the light intensity and produces pulse width modulated signals which drive an IR to switch Light to get necessary outcomes. This automated street light runs on solar energy and works based on atmospheric sunlight, and when evening falls, this circuit detects darkness. If the moment of human detects it via an IR sensor, the Light is on automatically. If there is no motion, the Light goes off. The voltage sensor is utilized for any change in the input parameter. MQ sensor is used for various gas parameters in the atmosphere; thus, depending on parameter changes, the data is used to upload in the cloud using a technology called IOT. This technology will facilitate fault identification and maintenance and minimizes the workforce by remotely monitoring each of the sensors in streetlights.

Keywords— IOT, IR, LDR, relay sensors, ESP 8266, Solar Panel.

I. INTRODUCTION

Automation is becoming increasingly prominent in the global economy and our everyday routines. Automated systems are preferred over manual approaches in numerous areas, including street lighting. A suitable term for this concept is "Smart Street Light Sensing" or Intelligent lighting detection includes incorporating Street illumination that adjusts depending on the presence and movement of people, cyclists, and automobiles in public spaces. Intelligent street lighting, sometimes termed adaptive street lighting, reduces its brightness in the absence of activity and increases it when motion is detected. This approach differs from conventional stationary or predetermined dimming street lighting methods.

Automation surpasses mere mechanization in the realm of industrialization, as it provides technological assistance to human operators, reducing reliance on human senses and cognitive capabilities. Street lighting holds paramount importance in this context. The concept itself is straightforward, the rise of urbanization and higher traffic density pose challenges in developing an effective street lighting system. Key considerations for such a system include prioritizing safety during the night, community members and road users benefit from enhanced visibility and safety, achieving cost-effective and widespread illumination, addressing crime rates, and minimizing the environmental impact. These aspects collectively contribute to the development of an efficient street lighting infrastructure.

In the past, street lights were manually operated using individual control switches for each lamp, marking the initial generation of street lighting. Another widely used method was optical control, which employed high-pressure sodium lamps. This approach has gained widespread adoption throughout the country. To automate street lighting, the optical control circuit employs a light-sensitive device that adjusts resistance, turning it on and switching it off at dawn. With the advancements in technology, street lighting systems can now be categorized based on their installation area and performance, catering to specific needs such as traffic routes, subsidiary roads, urban areas, and public amenity areas. Wireless Sensor Networks (WSN) play a crucial role in expanding the network's ability to sense and monitor street lighting is enhanced.

When addressing streetlight systems, a wide range of options is accessible, contingent upon the bulb type employed. The selection of lighting alternatives is extensive, encompassing various types like fluorescent, mercurial gas, metallic halide, high-pressure, low-pressure, dense luminescent, and light bulbs. These lighting choices appeal to diverse needs and interests. We have a range of lighting options available that can be tailored to suit various requirements and uses. Design incorporates a diverse range of technologies to meet specific requirements, taking into account factors such as luminous efficiency, lamp lifespan, and other pertinent considerations. Light-emitting diode lighting holds great promise as a viable solution for contemporary street lighting systems, thanks to its beneficial characteristics and advantages. The gradual replacement of conventional street lamps like incandescent, fluorescent, and high-pressure sodium lamps with light-emitting diode technology is anticipated in the future. Nonetheless, the adoption of light-emitting diode technology necessitates sophisticated



production facilities, high-quality materials, and precise manufacturing processes. Hence, this study focuses on enhancing energy efficiency in The street lightingsystem can be enhanced by integrating light-emitting diode bulbs. & leveraging a near-IR network for controlling & administration.

"Three individuals, namely George, A.M., George, V.I., and George, M.A., are involved in this project." [1]. To address these issues, this project incorporates the use of IoT with the (ANFIS) to enhance traffic situations. The study focuses on the development of an ANFIS traffic light controller and utilizes the MATLAB SIMULINK environment for its implementation. The controller takes inputs such as waiting time and vehicle density into consideration. Additionally, research incorporates the integration of a camera to capture real-time traffic situations. The Arduino UNO and the Thing Speak Platform securely upload these images to the cloud. On the server side, the received images undergo processing and analysis to facilitate further evaluation and decision-making. The images are processed using the ANFIS controller, which generates

appropriate control signals to be transmitted to traffic signals. This approach enables efficient traffic management and optimization without relying on traditional manual control methods.

Abed, M.M. and Younis, M.F: [2] In the current world, individuals desire an easy livelihood with the advantages of technological technology. The IoT has revolutionized various sectors, including health monitoring, traffic management, agriculture, street lighting, and education. However, the current manual operation of street lights results in significant energy wastage on a global scale, necessitating a change. This study focuses on the implementation of IoT to create an intelligent street lighting system that aligns with present-day requirements. By exploring the application of IoT in this context, we aim to address the energy efficiency and effectiveness of the street lighting in a smart and innovative manner. The expansion of the interconnection of various physical objects has emerged with the advent of IoT., aiming to improve human life by collecting data from the environment.

Mahesh Boda and Raju Athe developed the IoT-based Intelligent Street Lighting Network.[3] In this project, they utilized an LDR sensor and relay to detect the sunlight so that in the morning, the light will switch off, and the light will come on at night, and the data is sent to an IOT server with an ESP8266.

M. P. Gajare, Abhijeet Deshpande, and Laxman Aulwa describe the IoT-based Streetlight Automation System. [4] The intelligent street lighting system features an ATmega32 microprocessor that permits the switching on and off of street lights depending on predetermined time delays. It also transmits updates to a control centre via a server. This clever technique simplifies the administration of street lighting installations. The system has two primary modules: Within the system, two key components are present: the Data Control Unit (DCU) and the server side. The DCU comprises a microprocessor that establishes connections with RF modules and is linked to a GSM module. Conversely, the server side is composed of a web server based on Java, housing a core engine responsible for user interaction, database management, and communication with the GSM communication manager. These components work in tandem to ensure efficient functioning and seamless communication within the system. This complete arrangement allows effective communication and management of the street lighting system.

The authors of this research paper are Rudra war, O. Dagan, S. Chadha, J.R. & Kul kami, P.S.[5] This concept introduces "an intelligent system designed to efficiently regulate the intensity of street lights". The system incorporates a TRIAC-based circuit for controlling light intensity. By adjusting the voltage delivered to the circuit, which is proportional to the light intensity, the TRIAC enables precise regulation. The system dynamically adjusts the light intensity based on traffic conditions detected by sensors, optimizing energy usage.[6] Moreover, it automatically activates or deactivates based on accurate sunrise and sunset data obtained from reliable online sources. By combining power electronics, IoT devices, and dedicated software, this fully autonomous system effectively reduces unnecessary power consumption in street lighting. Additionally, a user-friendly graphical interface (GUI) allows monitoring and manual intervention during emergencies or exceptional circumstances.

II. PROPOSED SYSTEM

This project focuses on the implementing streetlight system using cloud technology to achieve enhanced control. By leveraging cloud technology, we aim to improve the management of street lights. The project involves the integration of various components, including the ESP8266 Wi-Fi module, Relay, IR sensor, LDR sensor, MQ-135 sensor, and MQ-2 sensor.

In India, street lighting maintenance poses a significant challenge. Currently, street lights are manually operated, resulting in electricity wastage due to human errors such as keeping the lights on during the daytime. To overcome these issues and enable more efficient communication, we are utilizing IoT technology for intelligent control and monitoring, minimizing human-related faults.

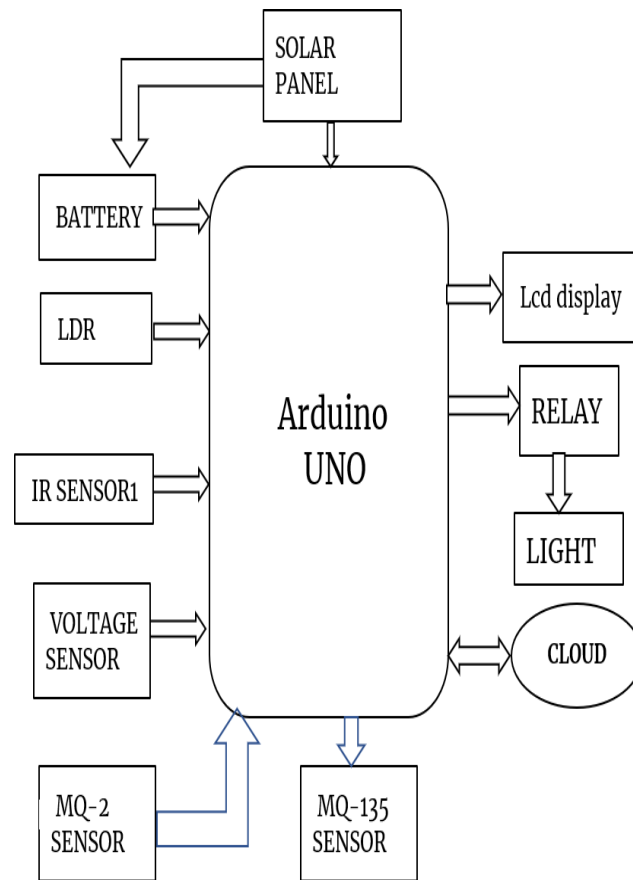

Fig: Block Diagram

III. THE WORKING CONDITION

The term "Internet of Things (IoT)" describes the revolutionary concept that digitally integrates electronic devices, bringing forth new opportunities for seamless interaction. By connecting these devices to the same network, information can be effortlessly and user-friendly transmitted to a smart device within the system.

The system architecture is designed to be adaptive and consists of several components, including LDR, IR, MQ2, MQ135 & voltage sensors, an ESP8266, a relay, and a light. The Arduino serves as the central processing unit for the entire system. All sensors utilized in this setup are connected to the Arduino.

The LDR sensor, also known as a light-dependent resistor, demonstrates a unique characteristic where its resistance decreases in response to daylight, leading to the turning off light. Conversely, during night-time, when the sensor receives no light, its resistance increases, triggering the light to turn on.



The system also incorporates the use of Infrared (IR) technology. It intelligently adjusts the light intensity, dimming it when no activity is detected and brightening it upon detecting movement. Additionally, the system increases the brightness of the light in response to the presence of fog with the help of TRIAC.

As the Arduino code executes and triggers the TRIAC, the power flowing through the AC load will vary based on the conditions set by the Arduino. By adjusting timing and conditional angle, you can control the power delivered to the load, thereby achieving dimming of the light.

The relay, coupled to the Arduino through a relay driver, acts as an automated electromagnetic switch. It is a highly reliable component that automatically controls the switching on and off of the lights.

The MQ2 sensor is purpose-built to detect smoke particles, It serves a significant function in identifying the presence of smoke in the atmosphere around it. As the level of smoke concentration rises, the sensor initiates a gradual increase in light intensity. This characteristic enables the system to detect and monitor smoke effectively, ensuring efficient smoke detection capabilities within the setup.

The MQ135 sensor serves as a gas sensor, specializing in the detection of harmful gases. Its primary purpose is to identify the presence of noxious gases and transmit this information to an IoT server. By promptly reporting such data, the sensor enables real-time monitoring, and facilitates swift response to potential gas-related hazards.

IV. METHODOLOGY

The intelligent streetlight system that incorporates cloud computing comprises several essential components. Initially, the system employs various sensors such as LDR, IR, voltage, MQ2, MQ135, and a TRIAC to collect data on ambient light levels, the presence of individuals, movement, and air quality. This data is transmitted to a cloud server using an Arduino Uno and a wireless networking module. The cloud-based platform does data analysis, enabling intelligent decision-making. By utilizing the insights gained from the analysis, the system automatically adjusts the brightness and timing of the lamps, optimizing energy utilization. Furthermore, the cloud platform facilitates remote management and monitoring of streetlights. This approach ensures efficient and adaptable street lighting, resulting in enhanced energy efficiency and overall operational effectiveness.

V. RESULT

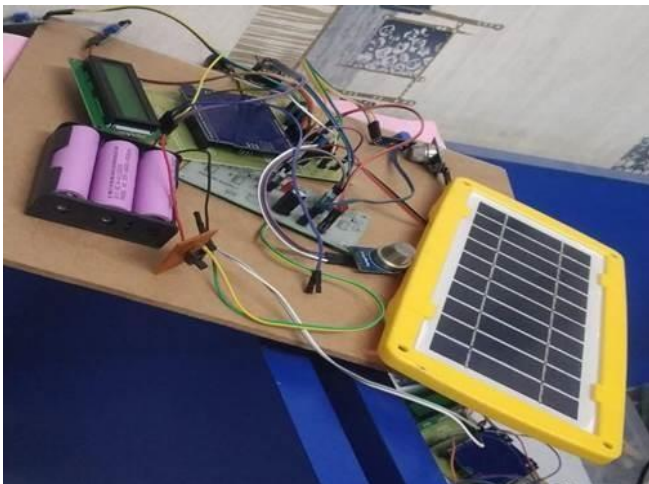

A. Scenario during the day

No LEDs are on at daylight, owing to full ambient brightness, and the value of LDR stays practically constant. The intensity fluctuates based on the light.

B. The scenario at Night

At night, due to the absence of ambient brightness, all LEDs are on at their maximum intensity, and the value of the LDR here also remains practically constant since the LDR would not perceive any light all night.

With the aid of the TRIAC, it can modify the brightness of the light when smoke is detected.

The figure below illustrates the data uploaded to the cloud server, providing a visual representation of the information stored in the cloud-based platform.



Hello.. street Welcome to IOT Server

Refresh

Switch to Graph View

Page 1 of 4 [Next](#)

S.No	LIGHT	IR	Gas	Smoke	Voltage	Date
1	1	0	1	1	12	2023-05-27 15:45:56
2	1	0	1	1	12	2023-05-27 15:45:38
3	1	0	1	1	12	2023-05-27 15:44:47
4	1	0	1	0	11	2023-05-27 15:44:24
5	1	0	1	0	11	2023-05-27 15:44:00
6	1	0	1	1	11	2023-05-27 15:43:42
7	1	0	1	0	11	2023-05-27 15:43:23
8	1	0	1	0	11	2023-05-27 15:43:05
9	1	0	1	0	11	2023-05-27 15:42:46
10	1	0	1	0	11	2023-05-27 15:42:28
11	1	0	1	0	11	2023-05-27 15:41:50
12	1	0	1	0	11	2023-05-27 15:41:31
13	1	0	1	0	11	2023-05-27 15:41:14
14	1	1	1	1	12	2023-05-08 17:05:27

Fig: Data stored in the think speak platform

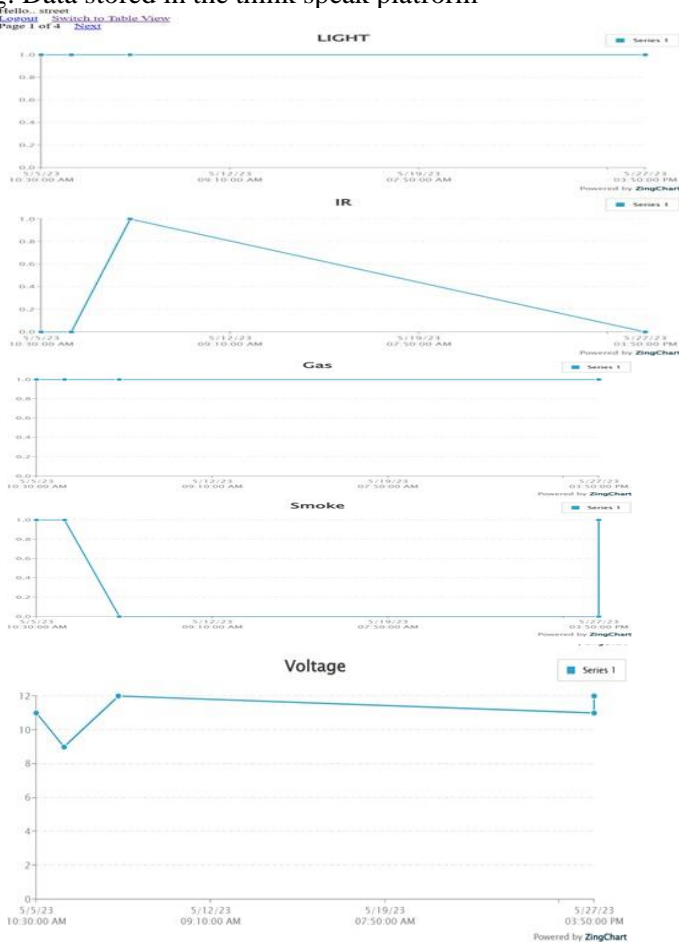

Fig: The Graphic view of the sensor.

The provided figure provides a clear depiction of the sensor's functioning, enabling easy comprehension of its operation.



THE CONCLUSION

The proposed system presents a simple and deployable solution that requires minimal maintenance compared to the current system. It can be enhanced by incorporating logic that retrieves accurate sunset and sunrise information from a reliable weather reporting source, enabling the automation of street light operations. This automated system guarantees the automatic Activation of the lights at sunset and their deactivation in the morning, Minimizing the requirement for human intervention. Physical visits to the street light locations will only be necessary in the event of issues. Automated systems offer greater efficiency compared to manual methods. Moreover, the system can enhance energy efficiency by dynamically adjusting the brightness of the lights according to the surrounding ambient light levels.

FUTURE SCOPE

The utilization of cloud technology in the smart street light system brings about several benefits, including enhanced energy efficiency, automated light control, real-time air quality monitoring, remote management capabilities, and integration of renewable energy sources

REFERENCES

1. George A.M & M.A, George V I, 2018, March this project incorporates the use of IoT with the (ANFIS) to enhance traffic situations.
2. M M. Younis & Abed, 2017. An innovative street lighting system using IoT technologies for adaptive luminescence.
3. Mahesh Boda and Raju Athe 2017, February. IoT-based intelligent & adaptable light in street lights 2017.
4. M. P. Gajare, Abhijeet Deshpande, and Laxman Aulwa 2016, October. describe the IoT-based Streetlight Automation System.
5. Rudra kumar, S. Chadha, Dagan & Kul kami, 2019, March. A sophisticated system devised to effectively control the intensity of street lights with intelligence.
6. Stephenraj, Kumar, N.N, & Arjun, 2019, March. An analysis of an IoT-based intelligent street lighting system published in the 2019, IEEE conference.